

ECHO



www.bearcatproducts.com

5 INCH CHIPPER/ SHREDDER/BLOWER

SC5720B - SUBARU 720cc

PARTS MANUAL



Manual P/N 77024-00
Rev. 010113
Companion to P/N 76869-00
VIN Range: 5VJAA0019DW003794 - Current

Before You Begin

DEAR ECHO BEAR CAT CUSTOMER

Thank you for purchasing a ECHO Bear Cat product. The ECHO Bear Cat line is designed, tested, and manufactured to give years of dependable performance. To keep your machine operating at peak efficiency, it is necessary to adjust it correctly and make regular inspections. The following pages will assist you in the operation and maintenance of your machine. Please read and understand this manual before operating your machine.

If you have any questions or comments about this manual, please call us toll-free at 1.888.645.4520.

If you have any questions or problems with your machine, please call or write your local authorized ECHO Bear Cat Dealer.

This document is based on information available at the time of its publication. ECHO Bear Cat is continually making improvements and developing new equipment. In doing so, we reserve the right to make changes or add improvements to our product without obligation for equipment previously sold.

PLEASE SEND US YOUR WARRANTY CARD

A warranty card is included in your owner's kit packaged with your machine. Please take the time to fill in the information requested on the card. When you send your completed card to us, we will register your machine and start your coverage under our limited warranty or go to bearcatproducts.com/warranty/warranty-registration/.

FOR MACHINE SERVICE OR PARTS:

For service assistance, contact your nearest authorized ECHO Bear Cat dealer or the factory. For parts, contact your authorized dealer. The parts manual for your machine is available at http://bearcatproducts.com/main/support/index_html. Your dealer will need to know the identification number of your machine to provide the most efficient service. See below for information on how to identify and record the identification number for your machine.

FOR ENGINE SERVICE OR PARTS:

For engine service or parts, contact your nearest authorized engine dealer. ECHO Bear Cat does not handle any parts, repairs or warranties for engines.

ORDERING PARTS

Only genuine ECHO Bear Cat replacement parts should be used to repair the machine. Replacement parts manufactured by others could present safety hazards, even though they may fit on this machine. Replacement parts are available from your ECHO Bear Cat dealer.

Provide the following when ordering parts:

The SERIAL NUMBER OR VIN of your machine.

The PART NUMBER of the part.

The PART DESCRIPTION.

The QUANTITY needed.

IDENTIFICATION NUMBER LOCATION

Your machine will have either a serial number or vehicle identification number (VIN). VINs are located on the left side of the trailer frame near the hitch. They are 17-digit numbers of the format: 5VJAA001XXWXXXXXX. Serial numbers are located on the machine body. They are 6-digit numbers.

Record your identification number in the space provided and on the warranty registration card.

SERIAL NUMBER OR VIN

HOW TO CONTACT ECHO BEAR CAT

ADDRESS	PHONE	E-MAIL	HOURS
237 NW 12th Street P.O. Box 849 West Fargo, ND 58078	888.645.4520 701.282.5520 FAX: 701.282.9522	sales@bearcatproducts.com service@bearcatproducts.com	Monday - Friday, 8 am to 5 pm Central Time

Is my machine CE Compliant?



The CE marking (also known as the “CE mark”) is a mandatory compliance mark on products sold internationally where CE standards are enforced and in the European Economic Area (EEA). The CE marking certifies that a product has met European Union (EU) consumer safety, health or environmental requirements. By affixing the CE marking to our products, Echo Bear Cat declares that it meets EU safety, health and environmental requirements.



Echo Bear Cat products that are CE compliant will be clearly marked with an identifying “CE” decal. These products feature safety and other engineering features that non-CE compliant products do not have. Non-CE compliant Echo Bear Cat products are primarily sold in countries and regions that do not require or enforce mandatory CE certification. However, this is not true for all countries and regions. If you are unsure of CE requirements for the country or region in which you live, please contact your nearest Echo Bear Cat dealer or distributor.

Other CE Model Identifying Decals



Echo Bear Cat products that are CE compliant will also be labeled with a decibal level warning decal. This decal notes the decibal level of noise created while the machine is operating under normal conditions.



Machine Mass: XXX kg (XXX lb)
Nominal Power: XX KW (XXX cc)
@ XXXX RPM

CE compliant Echo Bear Cat products will also have a CE compliance information decal detailing weight and power specifications for the specific model on which it is found.

CE Compliant Decal Location

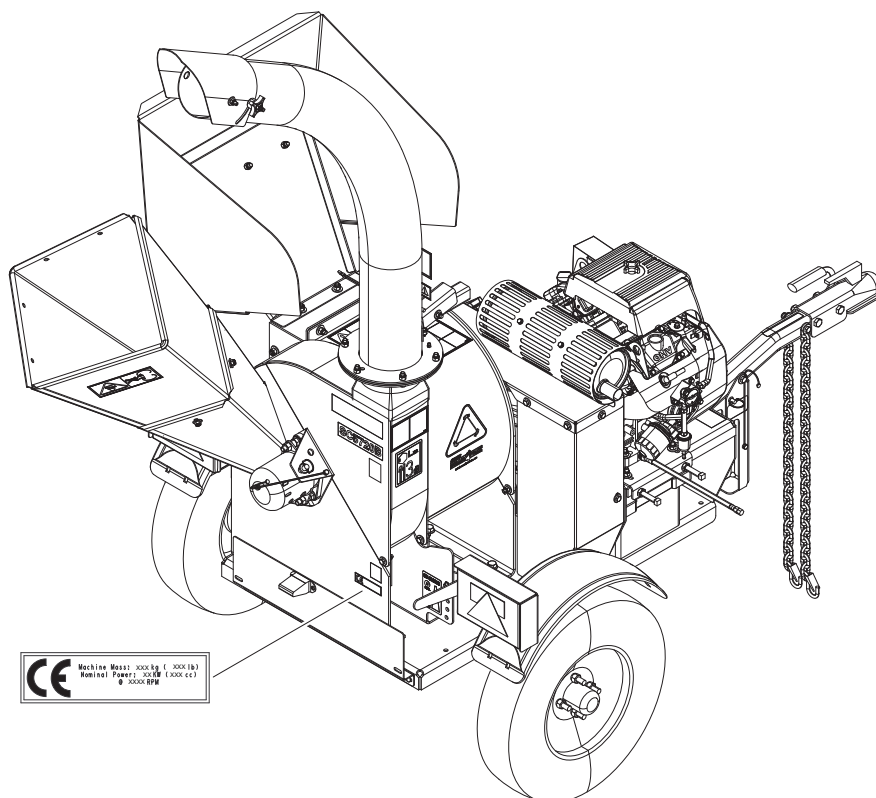
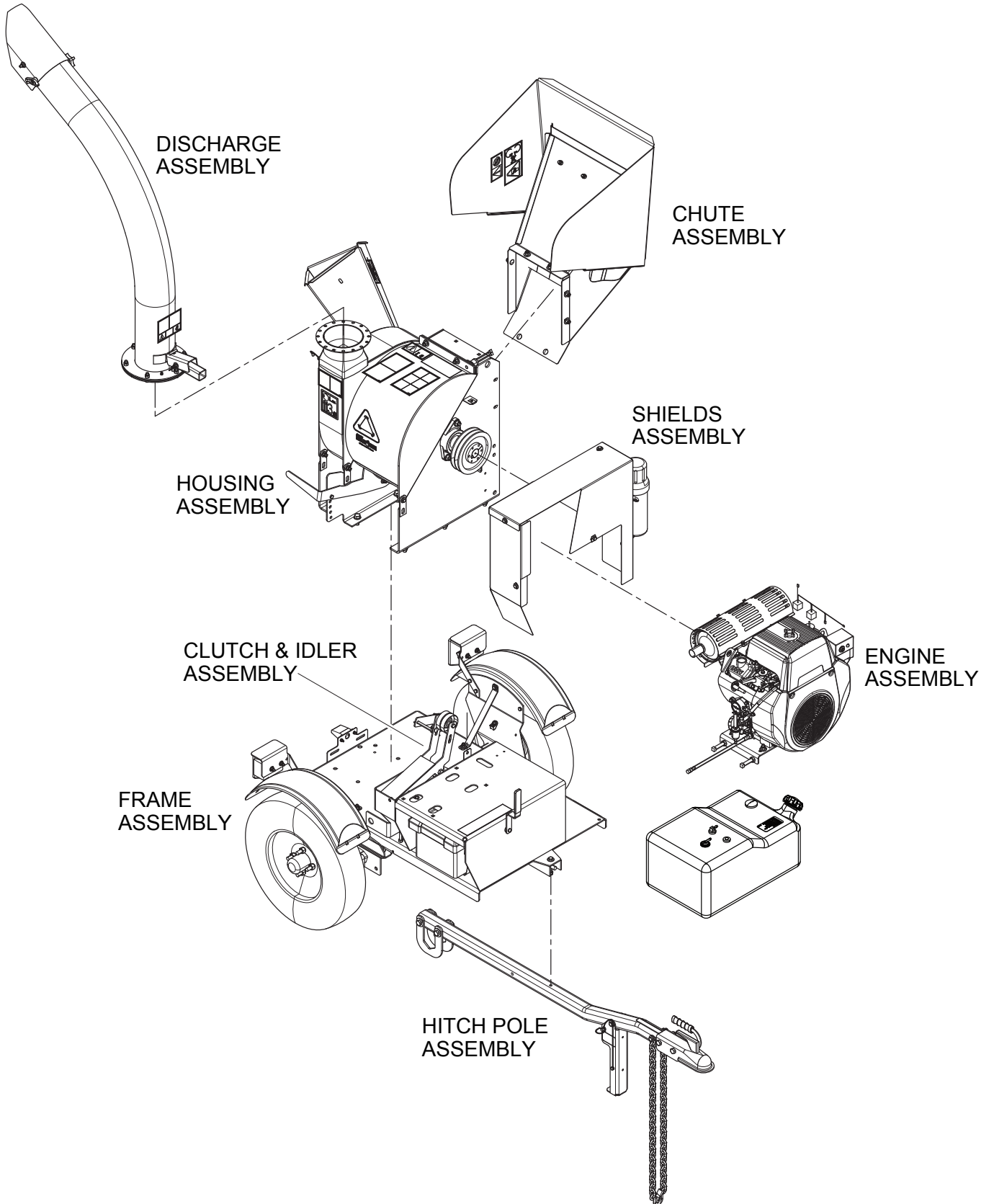
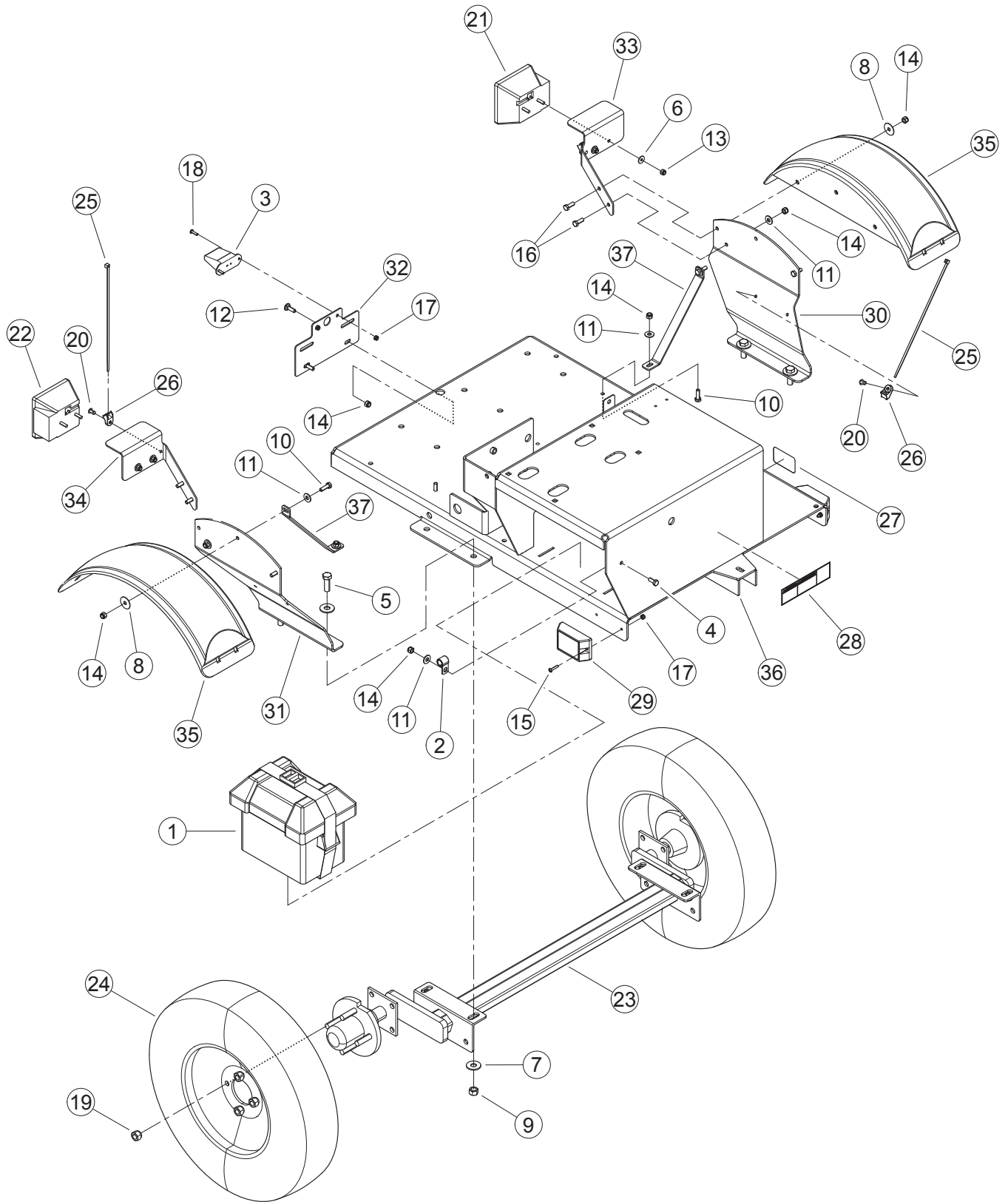

TABLE OF CONTENTS

DESCRIPTION	PAGE
EXPLODED VIEW.....	3
FRAME.....	4
NON-CE COMPLIANT	
FRAME.....	6
CE COMPLIANT	
HOUSING (A).....	8
HOUSING (B).....	10
SHIELDS.....	12
DISCHARGE CHUTE.....	14
ENGINE.....	16
IDLER.....	18
CHUTE.....	20
CHIPPER CHUTE EXTENSION.....	22
HITCH.....	24
NON-CE COMPLIANT	
HITCH.....	26
CE COMPLIANT	
CHIPPER/SHREDDER ROTOR COMPONENTS.....	28
SERVICE PARTS & ACCESSORIES.....	29





ITEM	PART NUMBER	DESCRIPTION
1	12839	BOX, SMALL BATTERY
2	14048-00	CLAMP, 9/16 COATED
3	14368-00	LIGHT, LICENSE PLATE
4	15003	BOLT, 5/16 X 3/4 HEX GR5 ZP
5	15014	BOLT, 1/2 X 1-1/2 HEX HD GR5 ZP
6	15030	WASHER, 1/4 FLAT ZP
7	15034	WASHER, 1/2 FLAT ZP
8	15040	WASHER, 5/16 FENDER ZP
9	15049	NUT, 1/2 CENTERLOCK GRB ZP
10	15219	BOLT, 5/16 X 1 HEX HD GR5 NC ZP
11	15250	WASHER, 5/16 FLAT ZP
12	15301	BOLT, 5/16 X 1 CRG GR5 ZP
13	15355	NUT, 1/4 NE NYLOCK ZP
14	15356	NUT, 5/16 NE NYLOCK ZP
15	15393	MACH. SCREW, 10-24 X 1 RND HD PHL ZP
16	15396	BOLT, 5/16 X 7/8 HEX HD GR5 NC ZP
17	15397	NUT, 10/24 NYLOCK TYPE NM, ZP
18	15460	MACH. SCREW, #10-24 X 3/4 PAN HD PH ZP
19	15527	NUT, 1/2-20 WHEEL
20	15828-00	RIVET, AL BLIND 1/4 X 3/4 DOME HEAD
21	16903	LIGHT, LH TAIL
22	16904	LIGHT, RH TAIL
23	16917	AXLE, 1000LB TORSION
24	16548	ASSEMBLY, 5.30-12 TIRE + SPOKE RIM
25	17320	STRAP, 11 IN. BLACK TIE
26	18549-00	CLAMP, CABLE MOUNT
27	32156-00	DECAL, 5.30-12 LOAD RATING
28	32330-00	DECAL, CHECK WHEELS
29	32347-00	LIGHT, AMBER SIDE MARKER
30	75541-12	BRACKET, LH FENDER
31	75542-12	BRACKET, RH FENDER
32	75543-12	PLATE, LICENSE
33	75548-12	BRACKET, LIGHT LH
34	75549-12	BRACKET, LIGHT RH
35	76624-00	FENDER, BLACK PLASTIC DRILLED
36	76834-12	WELDMENT, C/S TRAILER
37	76984-12	BRACE, FENDER
	32326-00	HARNESS, CHIPPER TRAILER

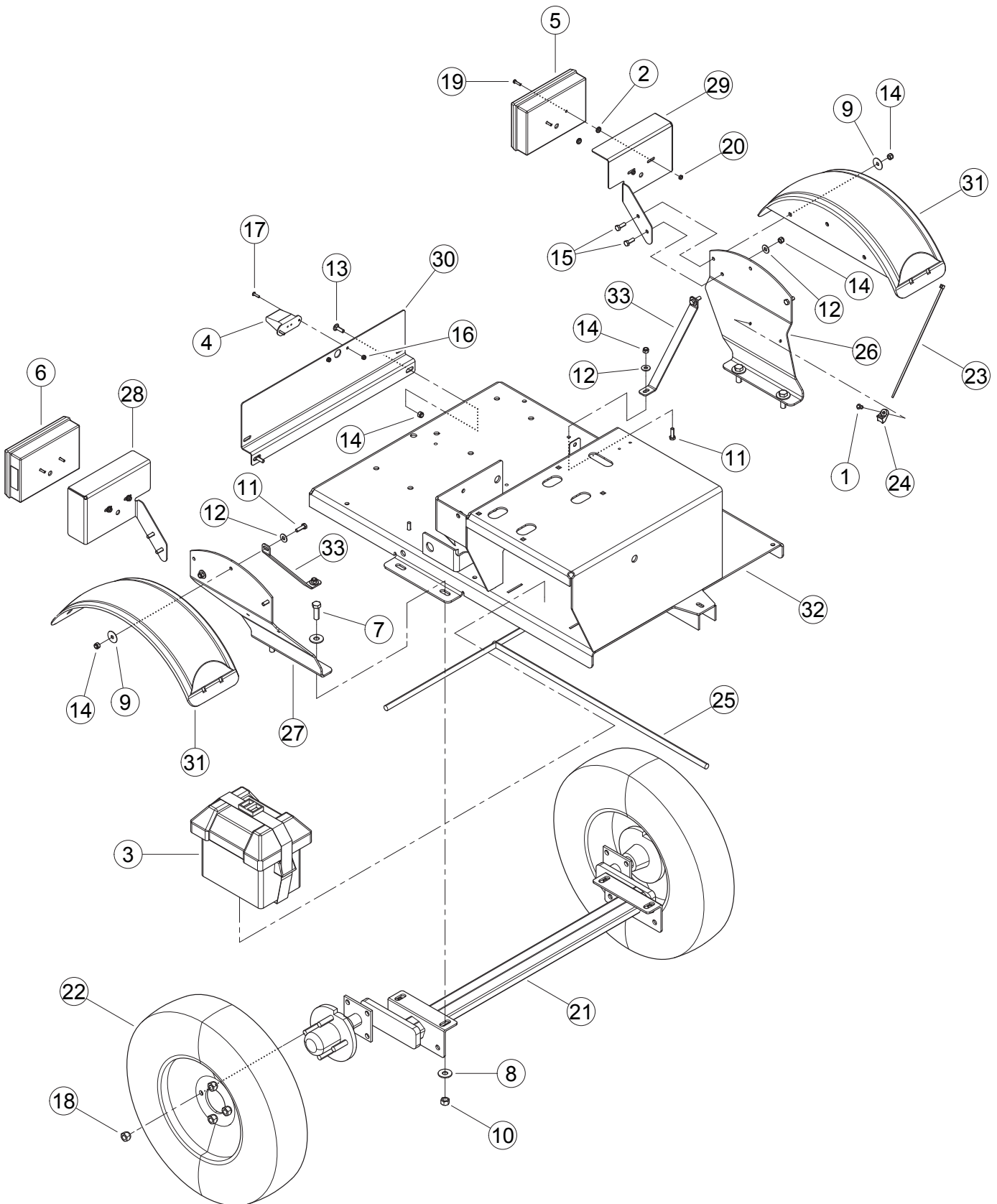

ITEM	PART NUMBER	DESCRIPTION
1	0111-0058-00	RIVET, 1/4 X 3/4 ST POP
2	0934-0004-00	GROMMET, 1/4 X 5/8 RUBBER
3	12839	BOX, SMALL BATTERY
4	14368-00	LIGHT, LICENSE PLATE
5	14566-00	LIGHT, TAIL RH
6	14580-00	LIGHT, TAIL LH
7	15014	BOLT, 1/2 X 1-1/2 HEX HD GR5 ZP
8	15034	WASHER, 1/2 FLAT ZP
9	15040	WASHER, 5/16 FENDER ZP
10	15049	NUT, 1/2 CENTERLOCK GRB ZP
11	15219	BOLT, 5/16 X 1 HEX HD GR5 NC ZP
12	15250	WASHER, 5/16 FLAT ZP
13	15301	BOLT, 5/16 X 1 CRG GR5 ZP
14	15356	NUT, 5/16 NE NYLOCK ZP
15	15396	BOLT, 5/16 X 7/8 HEX HD GR5 NC ZP
16	15397	NUT, 10/24 NYLOCK TYPE NM, ZP
17	15460	MACH. SCREW, #10-24 X 3/4 PAN HD PH ZP
18	15527	NUT, 1/2-20 WHEEL
19	15557	BOLT, 10-24 X 3/4 HEX HD GR8 PLAIN
20	15830-00	NUT, #10-24 K-LOCK ZP
21	16917	AXLE, 1000LB TORSION
22	16548	ASSEMBLY, 5.30-12 TIRE + SPOKE RIM
23	17320	STRAP, 11 IN BLACK TIE
24	18549-00	CLAMP, CABLE MOUNT
25	36202-00	HARNESS, C/S TRAILER
26	75541-12	BRACKET, LH FENDER
27	75542-12	BRACKET, RH FENDER
28	75553-12	BRACKET, LIGHT
29	75554-12	BRACKET, LIGHT
30	75555-12	PLATE, MOUNTING
31	76624-00	FENDER, BLACK PLASTIC DRILLED
32	76834-12	WELDMENT, C/S TRAILER
33	76984-12	BRACE, FENDER

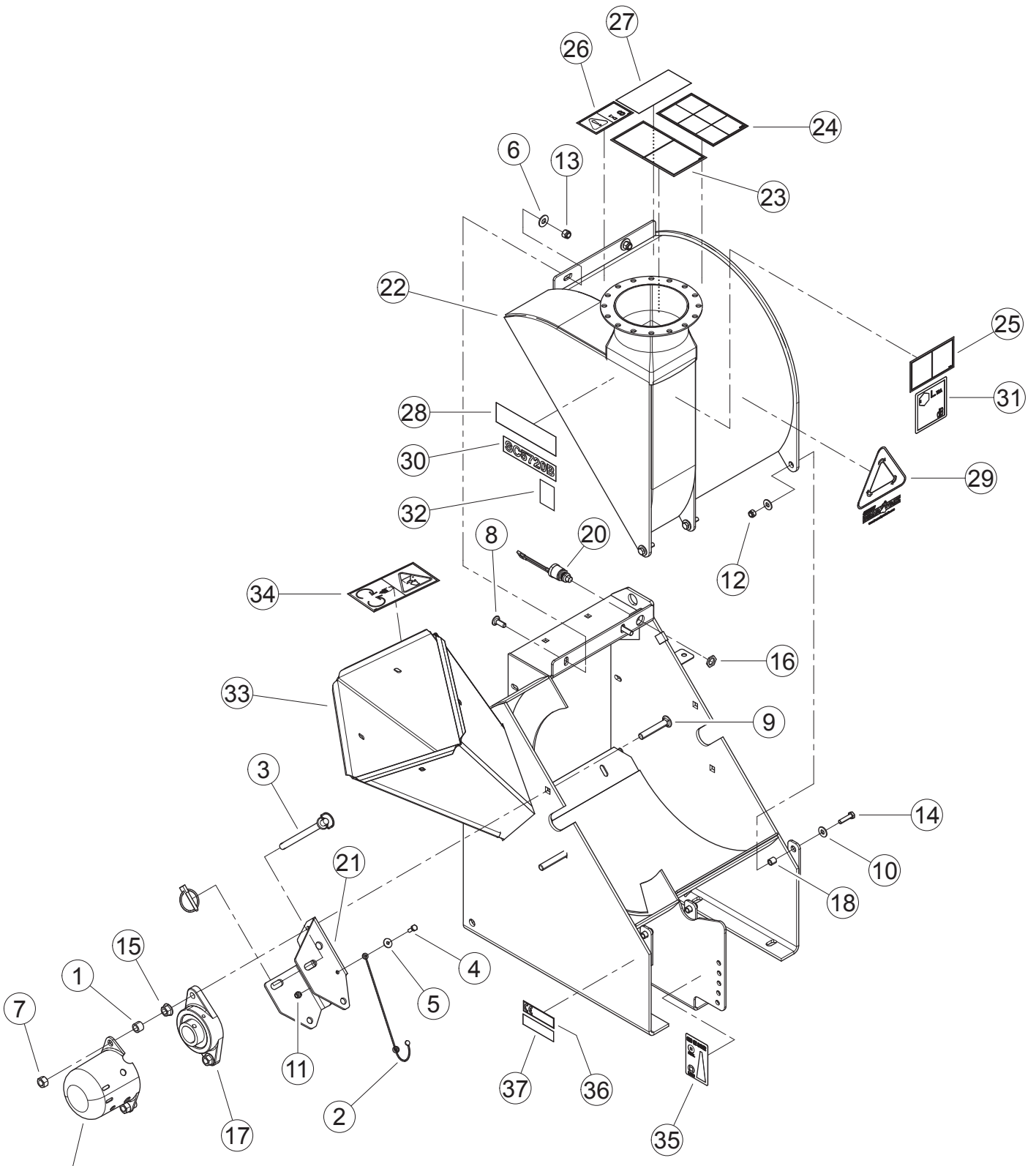

ITEM	PART NUMBER	DESCRIPTION
1	0311-0110-00	BUSHING, 1/2ID X 3/4OD X 17/32 LNST
2	12530	LANYARD, NYLON
3	14544-00	PIN, HITCH 1/2 X 6-1/2 W LYNCH
4	15001	BOLT, 1/4 X 3/4 HEX HD GR5 ZP
5	15030	WASHER, 1/4 FLAT ZP
6	15031	WASHER, 3/8 FLAT ZP
7	15049	NUT, 1/2 CENTERLOCK GRB ZP
8	15057	BOLT, 3/8 X 1 CRG GR5 NC ZP
9	15142	BOLT, 1/2 X 3 CRG GR5 ZP
10	15250	WASHER, 5/16 FLAT ZP
11	15355	NUT, 1/4 NE NYLOCK ZP
12	15356	NUT, 5/16 NE NYLOCK ZP
13	15388	NUT, 3/8 NE NYLOCK ZP
14	15436	BOLT, 5/16 X 1-1/4 GR5 HEX HD NC ZP
15	15616	NUT, 1/2 SERR FLANGE NC ZP
16	15775-00	NUT, 5/8-32 JAM
17	16004	BEARING, 2 BOLT FLANGE 1-1/2" BORE
18	73508-00	SPACER, .50 X .50
19	73895-00	CAP, LARGE SHAFT
20	76622-00	ASSEMBLY, SEALED SWITCH
21	76889-12	PLATE, ROTOR LOCK
22	77015-00	ASSEMBLY, HOUSING TOP 5" C/S/B, SERVICE PART (INCLUDES ITEMS 23 - 31)
23	12169	DECAL, KNIFE ACCESS ISO
24	12172	DECAL, OPERATING INSTRUCTIONS ISO
25	12173	DECAL, DISCHARGE ISO
26	12250	DECAL, MAINTENANCE ISO
27	14942-00	DECAL, MUTILINGUAL MANUAL
28	17913	DECAL, ECHO BEARCAT 6.82 X 1.90
29	31393-00	DECAL, SHRED IT
30	31467-00	DECAL, MODEL SC5720B
31	31502-00	DECAL, 120 DB
32	32392-00	DECAL, ECHO BEARCAT QR CODE
33	77469-00	ASSEMBLY, CHIPPER BOTTOM, SERVICE PART (INCLUDES ITEMS 34 & 37)
	77470-00	ASSEMBLY, CE CHIPPER BOTTOM, SERVICE PART (INCLUDES ITEMS 34 - 37)
34	12175	DECAL, BLADE DANGER ISO
35	13616-00	DECAL, SHRED SIZE
36	31646-00	DECAL, SC5720B INFORMATION
37	31890-00	DECAL, ATLANTIC BRIDGE LTD INFO

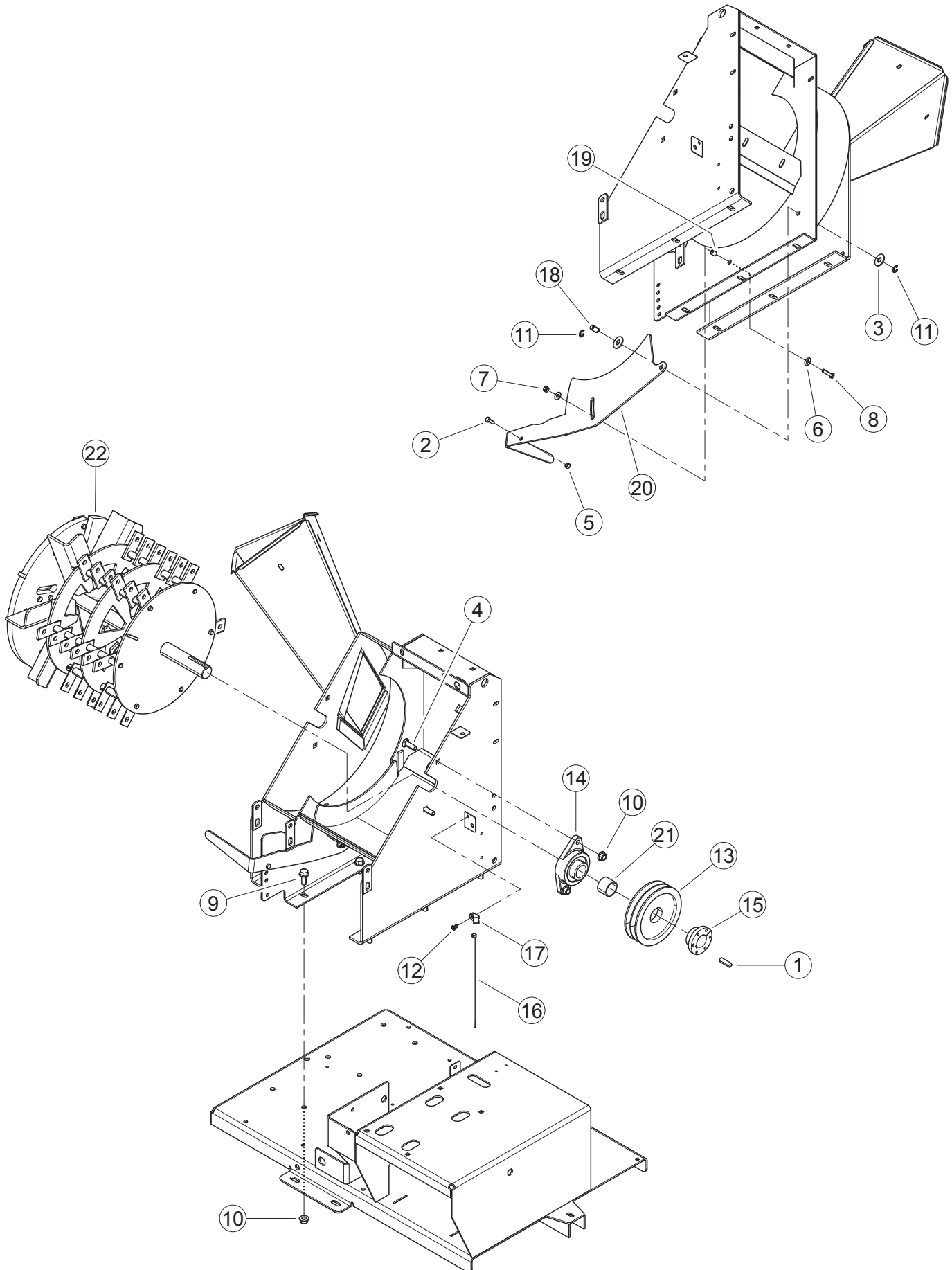

ITEM	PART NUMBER	DESCRIPTION
1	0122-0012-00	KEY, 3/8 SQUARE X 1-1/2 LONG
2	15003	BOLT, 5/16 X 3/4 HEX HD GR5 ZP
3	15034	WASHER, 1/2 FLAT ZP
4	15157	BOLT, 1/2 X 1-1/2 CRG GR5 ZP
5	15178	NUT, 5/16 CENTERLOCK NC ZP
6	15250	WASHER, 5/16 FLAT ZP
7	15356	NUT, 5/16 NE NYLOCK ZP
8	15436	BOLT, 5/16 X 1-1/4 HEX HD GR5 NC ZP
9	15612	BOLT, 1/2 X 1-1/4 SERR FLANGE
10	15616	NUT, 1/2 SERR FLZNGE NC ZP
11	15683-00	CLIP, 1/2" E
12	15828-00	RIVET, AL BLIND 1/4 X 3/4 DOME HEAD
13	16001	SHEAVE 2B 6.6 SDS
14	16004	BEARING, 2 BOLT FLANGE 1-1/2" BORE
15	16007	BUSHING, SDS 1-1/2"
16	17320	STRAP, 11 IN BLACK TIE
17	18549-00	CLAMP, CABLE MOUNT
18	73485-00	PIN, RETAINER
19	73508-00	SPACER, .50 X .50
20	76862-35	ADJUSTOR, SHREDDER
21	77143-12	SPACER, 1-3/4" OD X 1-1/2" ID X 1-1/4"
22	77612-00	ASSEMBLY, 5" CS ROTOR KNIVES

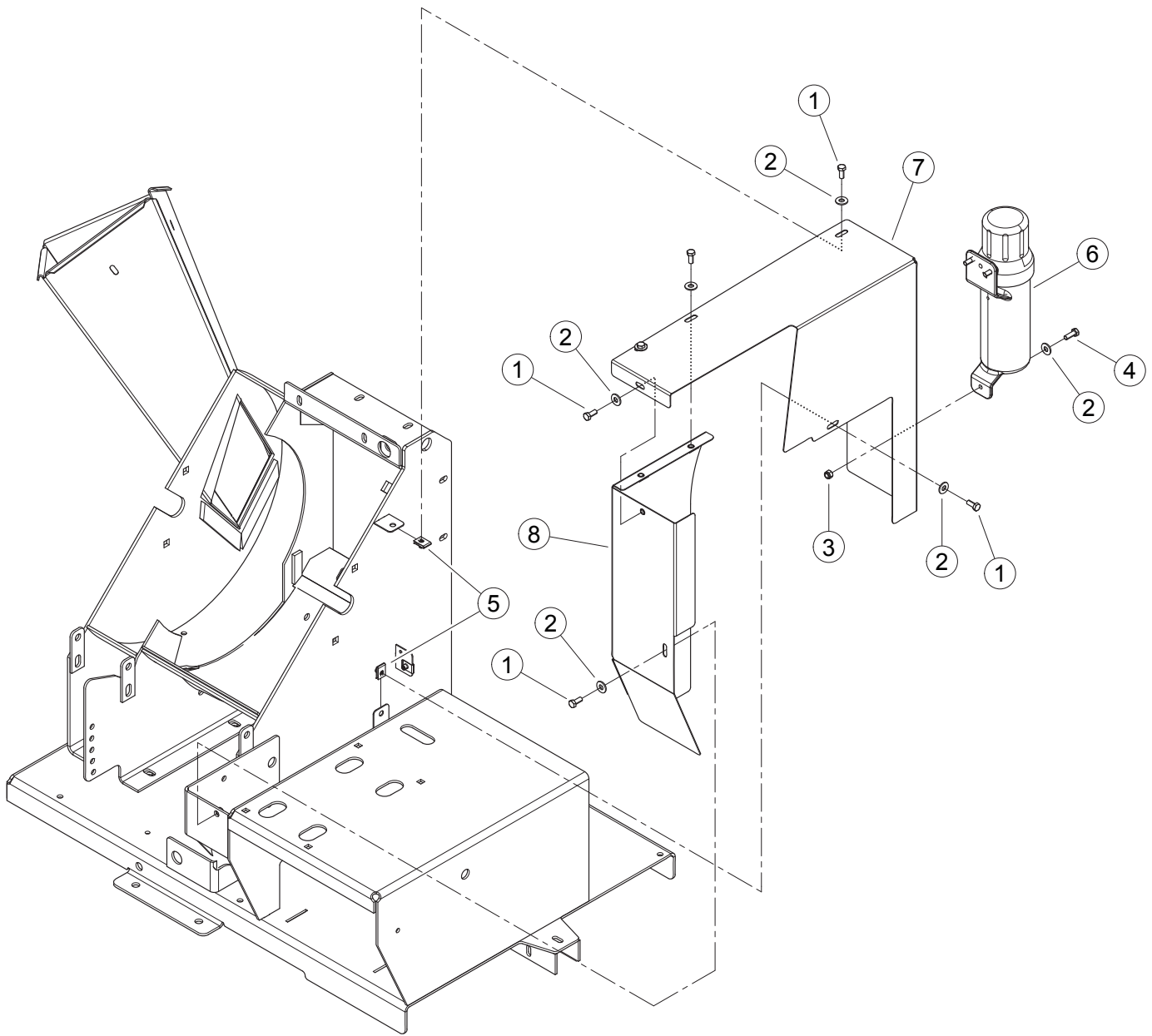

ITEM	PART NUMBER	DESCRIPTION
1	15003	BOLT, 5/16 X 3/4 HEX HD GR5 ZP
2	15250	WASHER, 5/16 FLAT ZP
3	15356	NUT, 5/16 NE NYLOCK ZP
4	15396	BOLT, 5/16 X 7/8 HEX HD NC GR5 ZP
5	15402	NUT, 5/16-18 TINNERMAN U-TYPE
6	18008-00	CONTAINER, MANUAL
7	76859-12	SHIELD, BELT
8	76860-12	WELDMENT, SHIELD

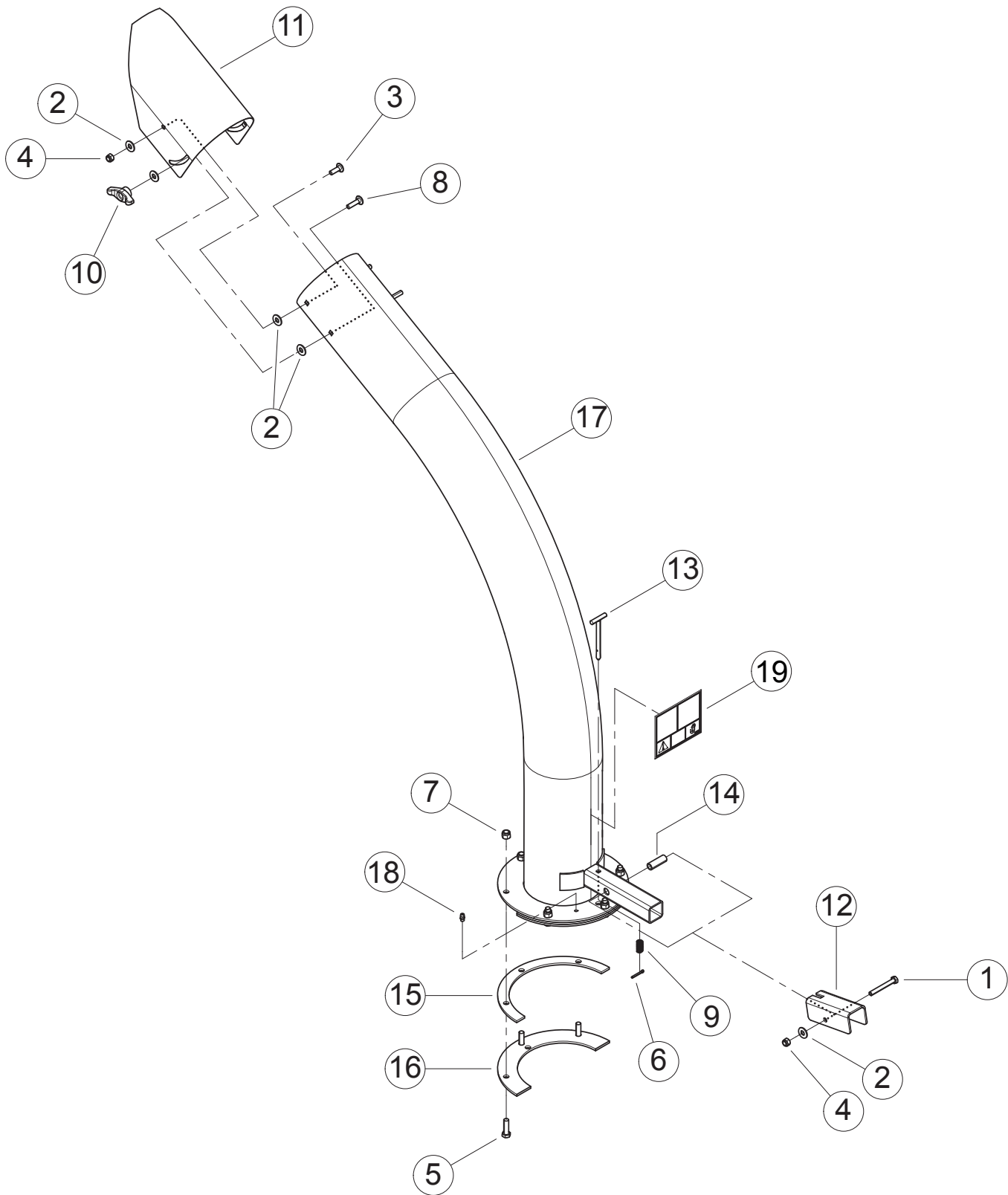

ITEM	PART NUMBER	DESCRIPTION
1	15154	BOLT, 5/16 X 2-1/2 HEX HD GR5 ZP
2	15250	WASHER, 5/16 FLAT ZP
3	15301	BOLT, 5/16 X 1 CRG GR5 ZP
4	15356	NUT, 5/16 NE NYLOCK ZP
5	15364	BOLT, 3/8 X 1-1/4 HEX HD GR5 ZP
6	15375	PIN, 1/8 X 1.00 COTTER ZP
7	15388	NUT, 3/8 NE NYLOCK ZP
8	15398	BOLT, 5/16 X 1-1/4 CRG GR5 ZP
9	16556	SPRING, LOCK COMPRESSION
10	31994-00	KNOB, 5/16-18 UNC TEE W/LOCKING INSERT
11	71081	DEFLECTOR, BLOWER-VAC DISCHARGE
12	71252	LEVER, DISCHARGE LOCK
13	71253	WELDMENT, DISCHARGE LOCK PIN
14	71256	TUBE, DISCHARGE LOCK PIVOT
15	72452-12	SPACER, DISCHARGE PIVOT
16	72453-12	RING, DISCHARGE CLAMP
17	77116-00	ASSEMBLY, 6 INCH DISCHARGE SERVICE PART
18	12275	FITTING, 1/4 SELF-TAP GREASE
19	32109-00	DECAL, DISCHARGE DEBRIS & LOCK

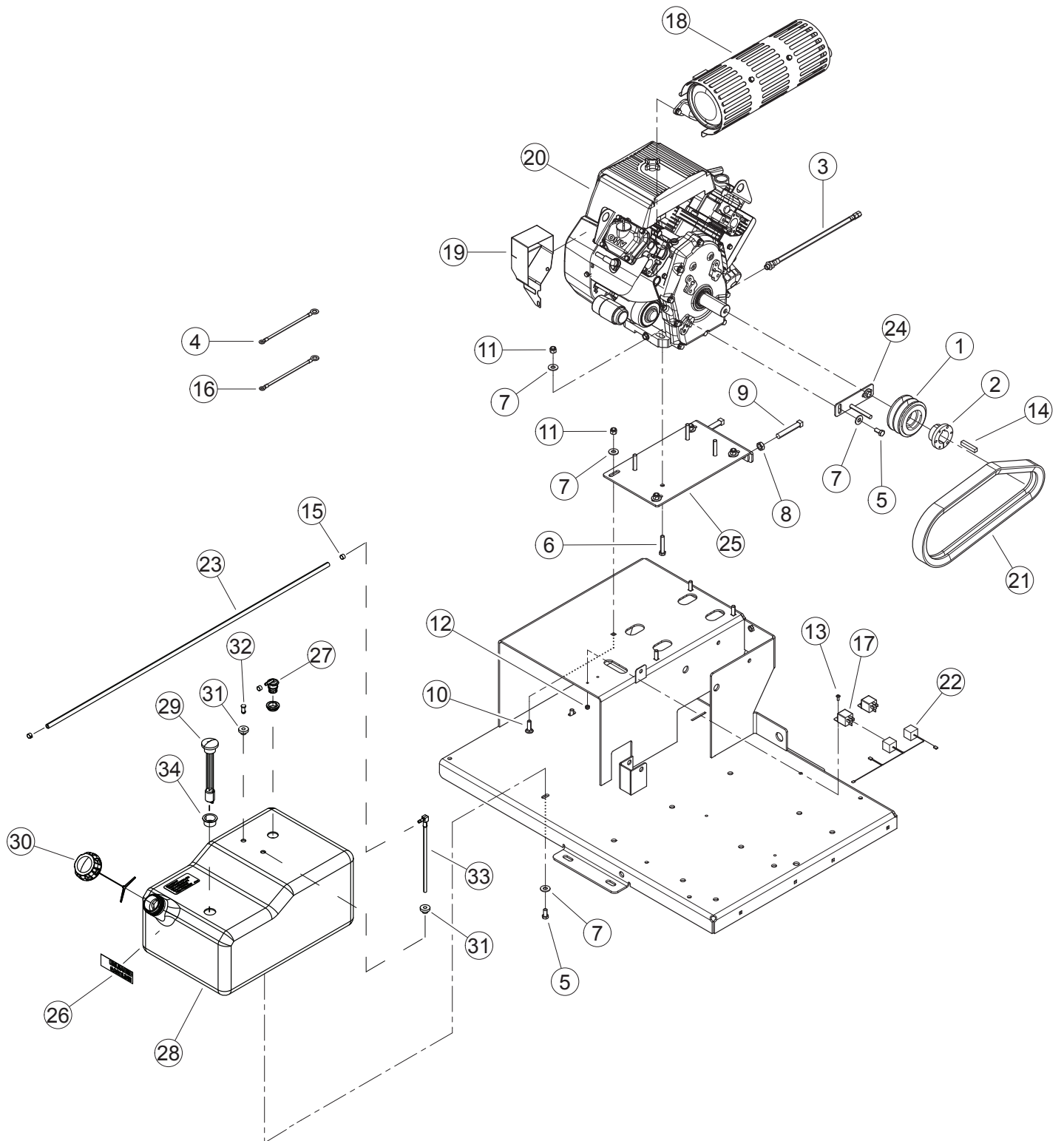

ITEM	PART NUMBER	DESCRIPTION
1	12446	SHEAVE, 2B3.6 SH, QD
2	13599-00	BUSHING, SH 1-7/16
3	14373-00	HOSE ASSY, CRANKCASE DRAIN
4	14901-00	CABLE, 24" NEG (R / R)
5	15005	BOLT 3/8*3/4 GR5 HEX CAPSCW ZP
6	15008	BOLT 3/8*2 GR5 HEX CAPSCREW ZP
7	15031	WASHER, 3/8" FLAT ZP (67PCS/LB)
8	15089	NUT, 1/2 NC ZP JAM
9	15285	SETSCREW, 1/2X3 SQ HD 1/2 DOG PT
10	15378	BOLT, CARR 3/8*1-1/4"GR5 NC ZP
11	15388	NUT, 3/8" NE NYLOCK ZP
12	15397	NUT, 10/24 NYLOCK TYPE NM, ZP
13	15423	SCW,MCH 10-24*1/2"PAN HD,PH ZP
14	15868-00	KEY, .375 X .230
15	16378	CLAMP, 15/32 SPRING
16	17888	CABLE, 33" POS (R / R WITH BOOT)
17	31238-00	RELAY, 12V SPDT W/ FLANGE
18		MUFFLER, SUBARU V-TWIN (FOR SERVICE SEE ENGINE OWNER'S MANUAL OR NEAREST AUTHORIZED SUBARU INDUSTRIAL ENGINE DEALER)
19		CONTROL, SUBARU V-TWIN IGNITION (FOR SERVICE SEE ENGINE OWNER'S MANUAL OR NEAREST AUTHORIZED SUBARU INDUSTRIAL ENGINE DEALER)
20		ENGINE, SUBARU 720CC EH72 (FOR SERVICE SEE ENGINE OWNER'S MANUAL OR NEAREST AUTHORIZED SUBARU INDUSTRIAL ENGINE DEALER)
21	31498-00	BELT, 2RB40
22	31610-00	HARNESS, CARB SAFETY RELEAY
23	75057-00	HOSE, 43 INCH FUEL LINE
24	76865-12	WELDMENT, BELT GUIDE
25	76978-12	WELDMENT, ENGINE ADJUSTER
	77711-00	ASSEMBLY, FUEL TANK
26	18982-00	DECAL, UNLEADED GASOLINE
27	32542-00	VALVE, ROLL OVER
28	32822-00	TANK, ROTOMOLDED FUEL
29	32823-00	GAUGE, FUEL LEVEL KELCH 100
30	32824-00	CAP, NON-VENTED EPA/CARB APPROVED
31	36689-00	GROMMET, TANK FITTING
32	36690-00	PLUG, TANK VENT
33	36694-00	FITTING, TANK FUEL PICK-UP TUBE
34	36696-00	GROMMET, KELCH 100 GAUGE

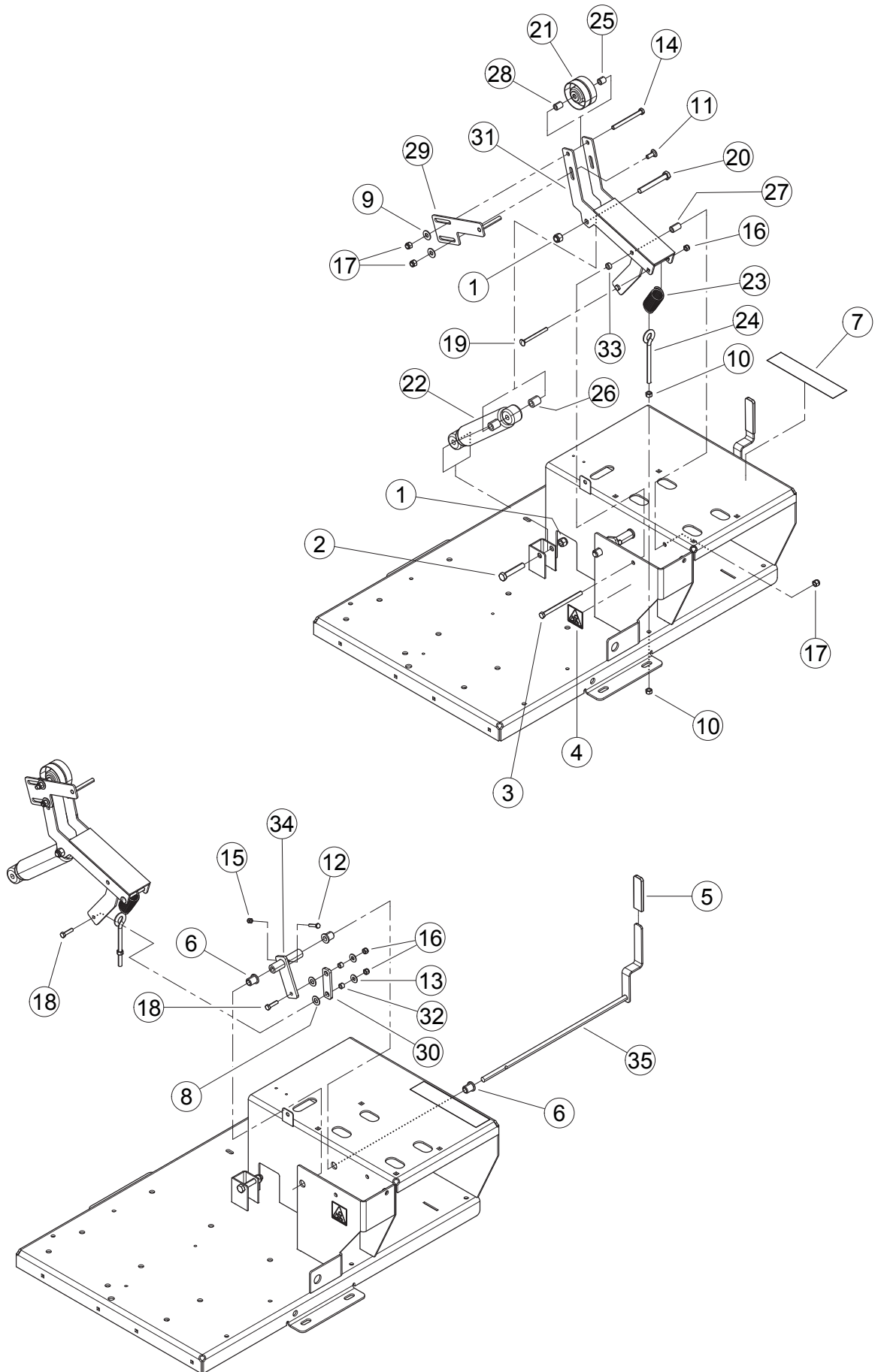

ITEM	PART NUMBER	DESCRIPTION
1	0101-0100-00	NUT, 1/2-13 UNC NYLOCK
2	0103-0756-00	BOLT, 1/2 X 2-3/4 HEX GR5 ZP
3	0103-0848-00	BOLT, 3/8 X 5-1/2 HEX GR5 ZP
4	12174	DECAL, SHIELD DANGER ISO
5	14076-00	GRIP, CLUTCH HANDLE
6	14236-00	BUSHING, 1/2 X 1 FLANGE LUBE
7	14302-00	DECAL, CHIPPER ENGAGEMENT
8	14640-00	NYLON WASHER, 1/2 INCH
9	15031	WASHER, 3/8 FLAT ZP
10	15042	NUT, 3/8 HEX NC ZP
11	15057	BOLT, 3/8 X 1 CRG GR5 NC ZP
12	15214	BOLT, 1/4 X 1-1/4 HEX HD GR5 ZP
13	15250	WASHER, 5/16 FLAT ZP
14	15272	BOLT, 3/8 X 4 HEX HD GR5 NC ZP
15	15355	NUT, 1/4 NE NYLOCK ZP
16	15356	NUT, 5/16 NE NYLOCK ZP
17	15388	NUT, 3/8 NE NYLOCK ZP
18	15436	BOLT, 5/16 X 1-1/4 HEX HD GR5 NC ZP
19	15536	BOLT, 5/16 X 3-1/2 CRG GR5 ZP
20	15549	BOLT, 1/2 X 3-3/4 HEX HD GR5 NC ZP
21	16319	PULLEY, 3-1/4 FLAT IDLER
22	16786	ABSORBER, IDLER SHOCK
23	17415	SPRING, 1.25 OD X 3.50 LG X .148 WD
24	17804	EYEBOLT, 3/8 X 5 LG 4-1/4 THD ZP
25	70362-12	SPACER, .63 X .63 PULLEY
26	70367	SPACER, .75 X .59
27	74991-12	SPACER, .63 X 1.035
28	75323-12	SPACER, 5/8 OD X 11 GA X .760
29	76847-12	WELDMENT, PIVOT ROD
30	76848-12	PLATE, CONNECTING ARM
31	76981-12	WELDMENT, IDLE ARM
32	76985-00	SPACER, 1/2" OD X 14 GA WA X 0.26"
33	76987-12	SPACER, 5/8" OD X 3/8" ID X 0.28"
34	77008-12	WELDMENT, PIVOT ARM
35	77011-12	WELDMENT, HANDLE

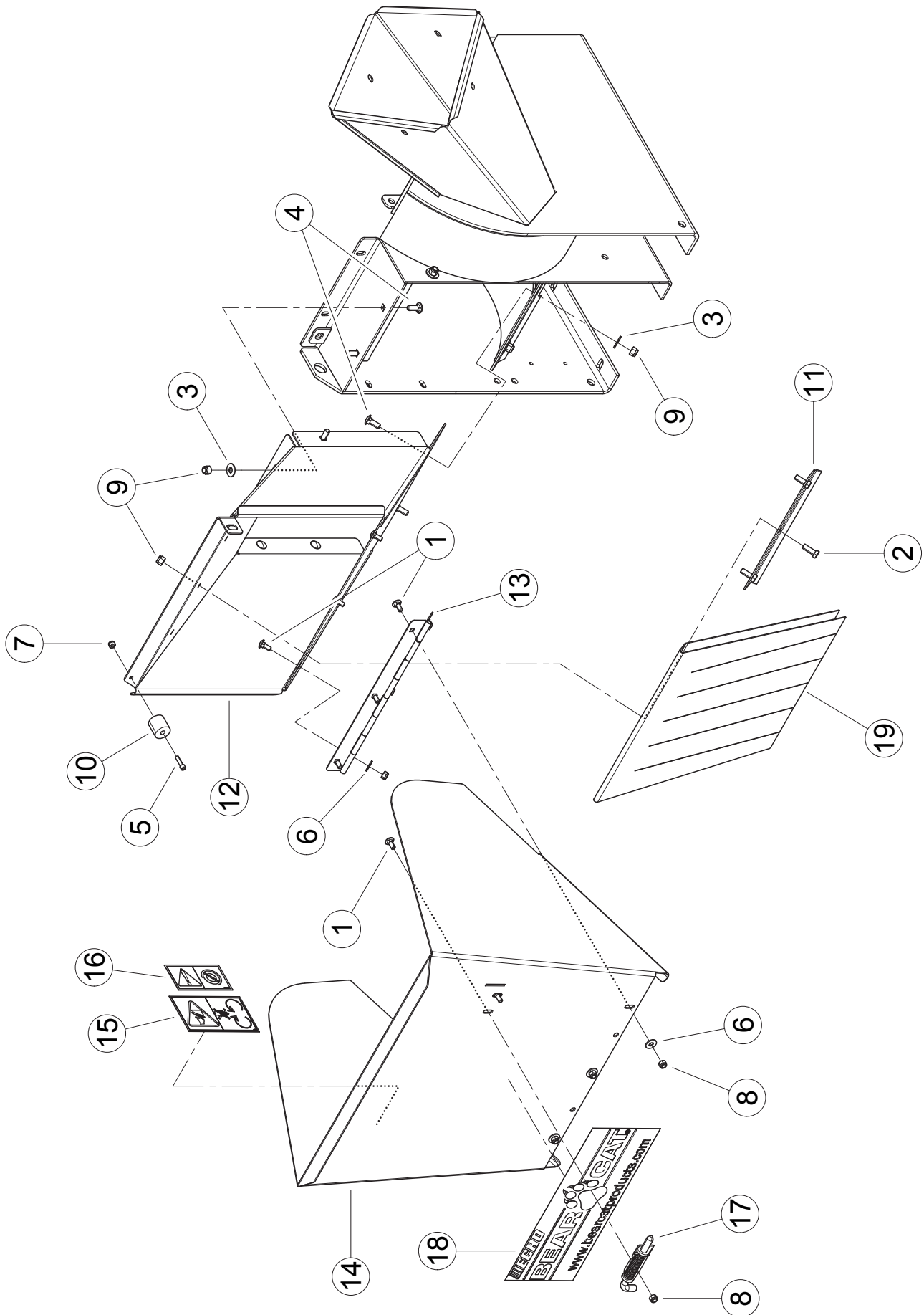

ITEM	PART NUMBER	DESCRIPTION
1	0103-0909-00	BOLT, 5/16-18 X 3/4 CRG SN GR5
2	15006	BOLT, 3/8 X 1 HEX HD GR5 ZP
3	15031	WASHER, 3/8 FLAT ZP
4	15057	BOLT, 3/8 X 1 CRG GR5 NC ZP
5	15242	BOLT, 1/4 X 1 SOC HD CAP SCRW
6	15250	WASHER, 5/16 FLAT ZP
7	15355	NUT, 1/4 NE NYLOCK ZP
8	15356	NUT, 5/16 NE NYLOCK ZP
9	15388	NUT, 3/8 NE NYLOCK ZP
10	18420-00	BUMPER, RECESSED RUBBER
11	73483-12	ANGLE, FLAP ANCHOR
12	76855-35	WELDMENT, CHUTE
13	76866-12	HINGE, EXTENSION TRAY
14	77002-00	ASSEMBLY, EXTENSION TRAY, SERVICE PART (INCLUDES ITEMS 1,8 & 15 - 18)
15	12175	DECAL, BLADE DANGER ISO
16	12176	DECAL, SHREDDER SIZE ISO
17	14971-00	LATCH, RH HINGE
18	31484-00	DECAL, BEARCAT WEB
19	77006-00	FLAP, C/S/B CHUTE

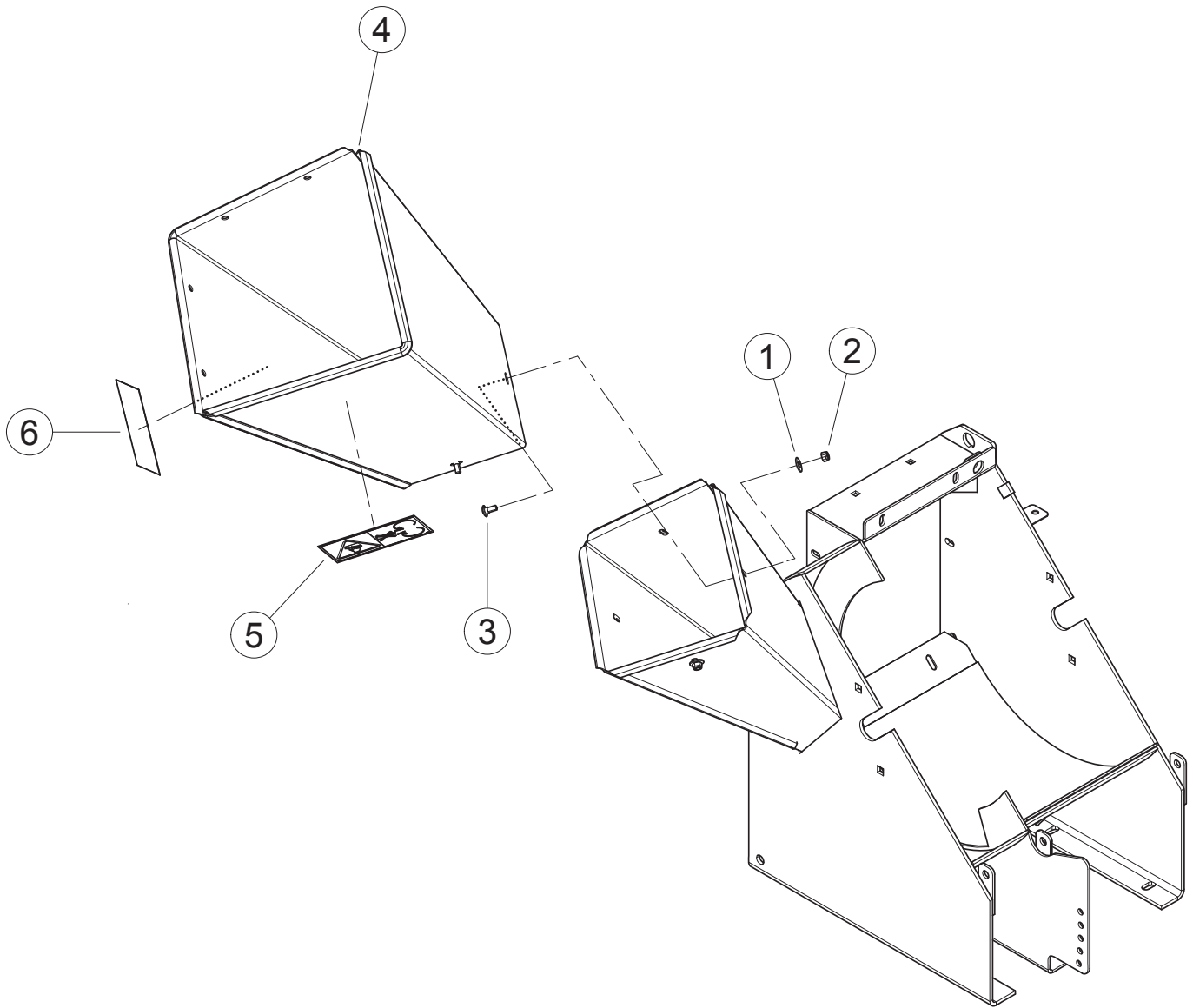

ITEM	PART NUMBER	DESCRIPTION
1	15250	WASHER, 5/16 FLAT ZP
2	15356	NUT, 5/16 NE NYLOCK ZP
3	15367	BOLT, 5/16 X 3/4 CRG GR5 NC ZP
4	71781	ASSY, COMM CHUTE EXTENSION W/DECAL (INCLUDES ITEMS 5-6)
5	12175	DECAL, BLADE DANGER ISO
6	14942-00	DECAL, MULTILINGUAL MANUAL

ITEM	PART NUMBER	DESCRIPTION
1	12530	LANYARD, NYLON
2	14048-00	CLAMP, 9/16" COATED
3	14381-00	CHAIN, SAFETY 5000 LB W/LATCH
4	14823-00	PIN, 3/8 HITCH
5	14940-00	HANDLE, HITCH COUPLER
6	15001	BOLT, 1/4 X 3/4 GR5 HEX HD ZP
7	15009	BOLT, 3/8 X 3 HEX HD GR5 ZP
8	15010	BOLT, 3/8 X 3-1/2 HEX HD GR5 ZP
9	15031	WASHER, 3/8 FLAT ZP
10	15034	WASHER, 1/2 FLAT ZP
11	15049	NUT, 1/2 CENTERLOCK GRB ZP
12	15173	BOLT, 1/2 X 3-1/4 HEX HD GR5 ZP
13	15355	NUT, 1/4 NE NYLOCK ZP
14	15388	NUT, 3/8 NE NYLOCK ZP
15	15501	BOLT, 3/8 X 3-1/4 HEX HD GR5 ZP
16	15827-00	RIVET, 1/4 X 1/2 AL BLIND DOME HEAD
17	17988	TRAILER HITCH COUPLER
18	18549-00	CLAMP, CABLE MOUNT
19	32327-00	DECAL, SAFETY CHAINS
20	32328-00	DECAL, TRAILER ELECTRICAL
21	32332-00	DECAL, SAFE COUPLING
22	76803-12	POLE, C/S HITCH
23	76804-12	STAND, JACK
24	76958-12	PLATE, HITCH
	17320	STRAP, NYLON TIE

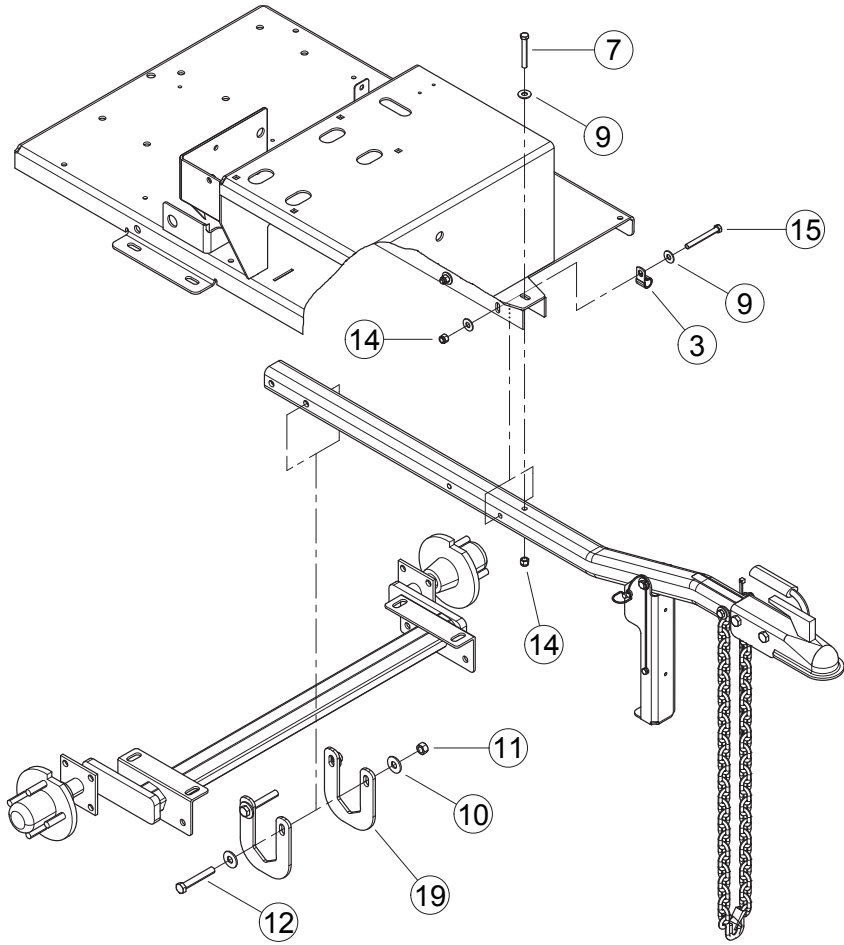
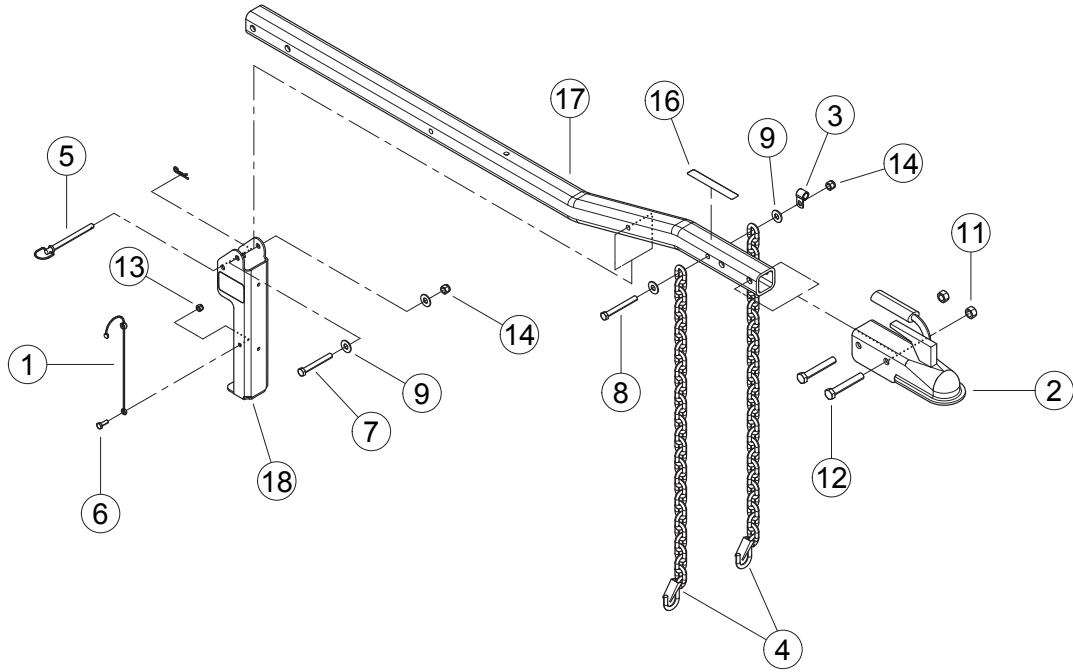

ITEM	PART NUMBER	DESCRIPTION
1	12530	LANYARD, NYLON
2	12536	COUPLER, 50 MM BALL
3	14048-00	CLAMP, 9/16" COATED
4	14381-00	CHAIN, SAFETY 5000 LB W/LATCH
5	14823-00	PIN, 3/8 HITCH
6	15001	BOLT, 1/4 X 3/4 HEX HD GR5 ZP
7	15009	BOLT, 3/8 X 3 HEX HD GR5 ZP
8	15010	BOLT, 3/8 X 3-1/2 HEX HD GR5 ZP
9	15031	WASHER, 3/8 FLAT ZP
10	15034	WASHER, 1/2 FLAT ZP
11	15049	NUT, 1/2 CENTERLOCK GRB ZP
12	15173	BOLT, 1/2 X 3-1/4 HCS GR5 ZP
13	15355	NUT, 1/4 NE NYLOCK ZP
14	15388	NUT, 3/8 NE NYLOCK ZP
15	15501	BOLT, 3/8 X 3-1/4 HEX HD GR5 ZP
16	16875	DECAL, HITCH LOAD
17	76803-12	POLE, C/S HITCH
18	76804-12	STAND, JACK
19	76958-12	PLATE, HITCH

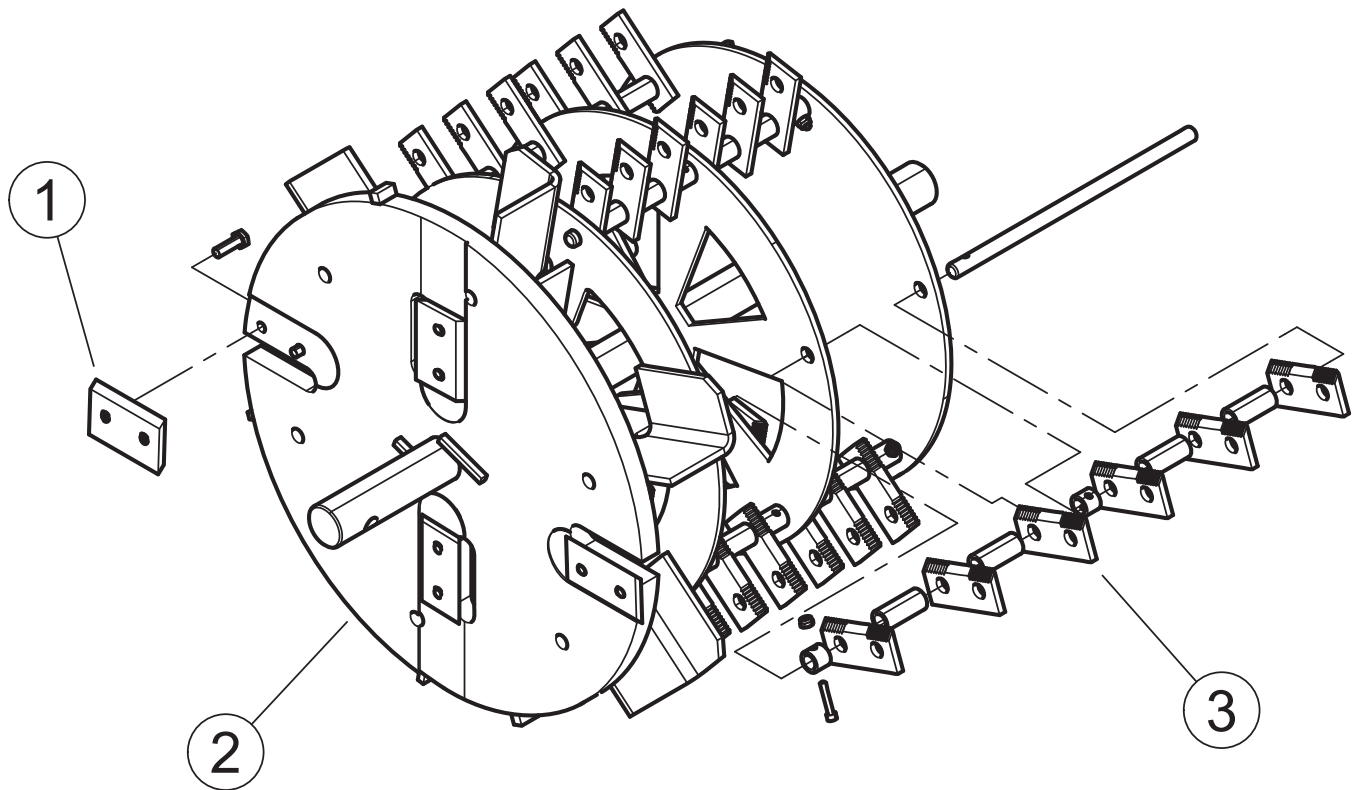

ITEM	PART NUMBER	DESCRIPTION
1		CHIPPER BLADE, FOR SERVICE ORDER KIT# 72493
	72493	KIT, CHIPPER BLADE
2	76844-00	WELDMENT, 5 INCH C/S ROTOR
3		SHREDDER KNIVES, FOR SERVICE ORDER KIT# 77613-00
	77613-00	KIT, SC5720B SHREDDER KNIVES

PART NUMBER	DESCRIPTION
77613-00	KIT, SHREDDER KNIFE
72493	KIT, CHIPPER BLADE



KIT, CHIPPER BLADE, 72493

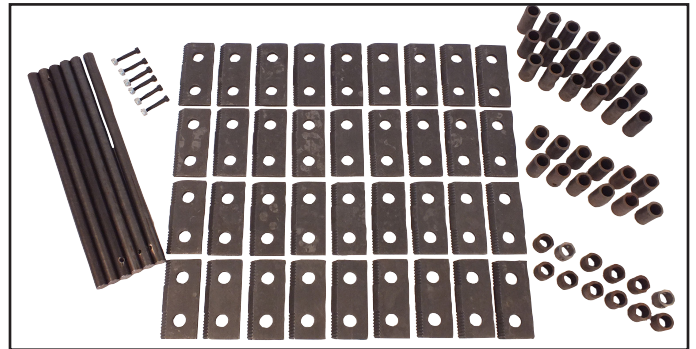

KIT, SHREDDER KNIFE, 77613-00



ECHO BEAR CAT

www.bearcatproducts.com

237 NW 12th Street, West Fargo, ND 58078-0849

Phone: 701.282.5520 • Toll Free: 888.645.4520 • Fax: 701.282.9522

E-mail: service@bearcatproducts.com • sales@bearcatproducts.com